

5GHz 15dBi High Gain Dual Polarization Directional Antenna

ANT-FP15AD

Installation Guide

1. Package Content

Thank you for choosing PLANET ANT-FP15AD. Before installing the Antenna, please verify the contents inside the package box.

- ANT-FP15AD x 1 unit
- Accessory (included screws and brackets) x 1 set

2. Specifications

Electrical Specifications	
Frequency range	5.150 – 5.875GHz
Max. Gain	15 ~ 16dBi
Antenna Type	Uni-directional, Flat Panel
V.S.W.R.	2.0:1 (max.)
Polarization	Linear, $\pm 90^\circ$
HPBW / Horizontal	$15^\circ \sim 19^\circ$
HPBW / Vertical	$17^\circ \sim 21^\circ$
Front to back ratio	-20dB (max.)
Isolation	25dB
Input Impedance	50 Ω
Cable	RG223, 150mm
Connector	N-Type (Female) x 2
Power handling	6W (cw)
Lightning Protection	DC ground

Environment & Mechanical Characteristics	
Survival Wind Speed	216Km/hr
Temperature	-40 ~ 80 Degree C
Humidity	95% @ 55 Degree C
Radome Color	Gray-white
Radome Material	ABS, UV resistant
Dimension (L x W x H)	210 x 210 x 73mm
Weight	800g
Weatherproof	IP55
Mount Type	Pole Mount or Wall Mount

Outlook:

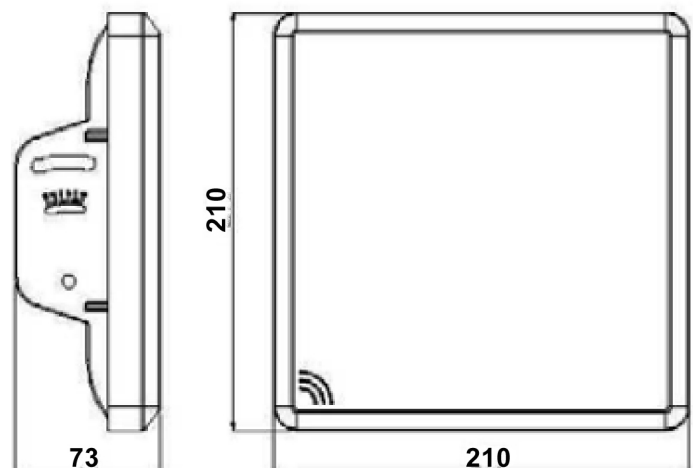

3. Mounting Configuration

Pole mount

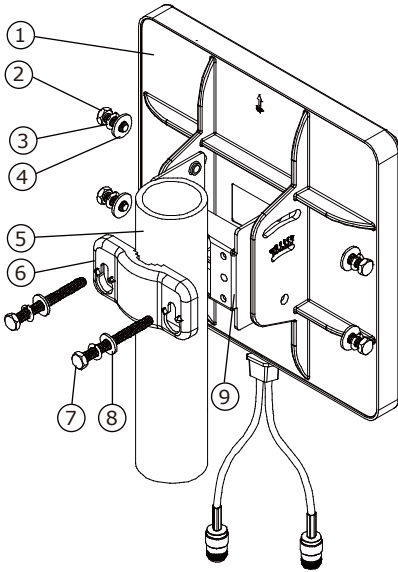

1. Antenna body - 1 pc
2. M6*16 screw - 4 pcs
3. M6 S/W- 6 pcs
4. M6 W (16mm) - 4 pcs
5. Pole (Max. 2inch)
6. Lock frame - 1 pc
7. M6*60 screw - 2 pcs
8. M6 W (12mm) - 2 pcs
9. M-shape mounting - 1 pc
10. Screw - 4 pcs
11. Anchor - 4 pcs
12. Wall

Wall mount

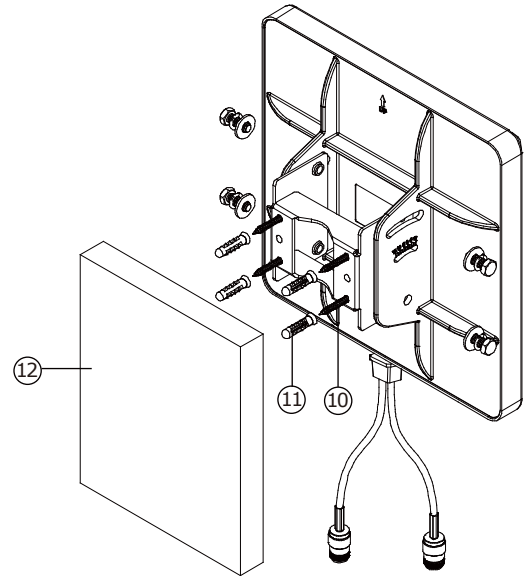

OUTDOOR INSTALLATION WARNING

IMPORTANT SAFETY PRECAUTIONS:

LIVES MAY BE AT RISK! Carefully observe these instructions and any special instructions that are included with the equipment you are installing.

CONTACTING POWER LINES CAN BE LETHAL.

Make sure no power lines are anywhere where possible contact can be made. Antennas, masts, towers, guy wires or cables may lean or fall and contact these lines. People may be injured or killed if they are touching or holding any part of equipment when it contacts electric lines. Make sure there is NO possibility that equipment or personnel can come in contact directly or indirectly with power lines. Assume all overhead lines are power lines.

The horizontal distance from a tower, mast or antenna to the nearest power line should be at least twice the total length of the mast/antenna combination. This will ensure that the mast will not contact power if it falls either during installation or later.

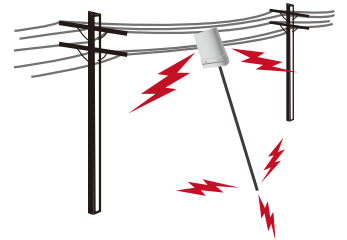

TO AVOID FALLING, USE SAFE PROCEDURES WHEN WORKING AT HEIGHTS ABOVE GROUND.

Select equipment locations that will allow safe, simple equipment installation.

- Don't work alone. A friend or co-worker can save your life if an accident happens.
- Use approved non-conducting ladders and other safety equipment. Make sure all equipment is in good repair.
- If a tower or mast begins falling, don't attempt to catch it. Stand back and let it fall.
- If anything such as a wire or mast does come in contact with a power line, DON'T TOUCH IT OR ATTEMPT TO MOVE IT. Instead, save your life by calling the power company.
- Don't attempt to erect antennas or towers on windy days.

MAKE SURE ALL TOWERS AND MASTS ARE SECURELY GROUNDED, AND ELECTRICAL CABLES CONNECTED TO ANTENNAS HAVE LIGHTNING ARRESTORS. This will help prevent fire damage or human injury in case of lightning, static build-up, or short circuit within equipment connected to the antenna.

- The base of the antenna mast or tower must be connected directly to the building protective ground or to one or more approved grounding rods, using 1 OAWG ground wire and corrosion-resistant connectors.
- Refer to the National Electrical Code for grounding details.

IF A PERSON COMES IN CONTACT WITH ELECTRICAL POWER, AND CANNOT MOVE:

- DON'T TOUCH THAT PERSON, OR YOU MAY BE ELECTROCUTED.
- Use a non-conductive dry board, stick or rope to push or drag them so they no longer are in contact with electrical power.
- Once they are no longer contacting electrical power, administer CPR if you are certified, and make sure that emergency medical aid has been requested.